

Features :

- Universal AC input / Full range
- No load power consumption < 0.3W
- ErP step2 compliant
- Meet EISA 2007 (Energy Independence and Security Act)
- 2 pole USA plug
- Class II power (without earth pin)
- Protections: Short circuit / Overload / Over Voltage / Over temperature
- Fully enclosed plastic case
- Approvals: UL / CUL / BSMI / CB / FCC
- Pass LPS for full series
- 2 years warranty

SPECIFICATION

ORDER NO.	GS12U05-P1I	GS12U07-P1I	GS12U09-P1I	GS12U12-P1I	GS12U15-P1I	GS12U18-P1I	GS12U24-P1I	
OUTPUT	SAFETY MODEL NO.	GS12U05	GS12U07	GS12U09	GS12U12	GS12U15	GS12U18	GS12U24
	DC VOLTAGE	5V	7.5V	9V	12V	15V	18V	24V
	RATED CURRENT	2.0A	1.6A	1.33A	1.0A	0.8A	0.67A	0.5A
	CURRENT RANGE	0 ~ 2.0A	0 ~ 1.6A	0 ~ 1.33A	0 ~ 1.0A	0 ~ 0.8A	0 ~ 0.67A	0 ~ 0.5A
	RATED POWER	10W	12W	12W	12W	12W	12.06W	12W
	RIPPLE & NOISE (max.) Note.2	75mVp-p	90mVp-p	90mVp-p	120mVp-p	150mVp-p	180mVp-p	200mVp-p
	VOLTAGE TOLERANCE Note.3	±5.0%	±4.0%	±4.0%	±3.0%	±3.0%	±3.0%	±3.0%
	LINE REGULATION Note.4	±1.0%	±1.0%	±1.0%	±1.0%	±1.0%	±1.0%	±1.0%
	LOAD REGULATION Note.5	±5.0%	±4.0%	±4.0%	±3.0%	±3.0%	±2.0%	±2.0%
SETUP, RISE, HOLD UP TIME	500ms, 20ms, 30ms/230VAC 500ms, 20ms, 10ms/115VAC at full load							
INPUT	VOLTAGE RANGE	90 ~ 264VAC		135 ~ 370VDC				
	FREQUENCY RANGE	47 ~ 63Hz						
	EFFICIENCY (Typ.)	74%	78%	78%	78%	79%	80%	80%
	AC CURRENT	0.31A / 115VAC		0.16A / 230VAC				
	INRUSH CURRENT (max.)	COLD START 25A / 115VAC		45A / 230VAC				
LEAKAGE CURRENT (max.)	0.25mA / 240VAC							
PROTECTION	OVERLOAD	>105% rated output power Protection type : Hiccup mode, recovers automatically after fault condition is removed						
	OVER VOLTAGE	115% ~ 135% Protection type : Clamp by zener diode						
	OVER TEMPERATURE Note.6	U1 Tj 140°C typically (U1) Detect on main control IC Protection type : Shut down o/p voltage, recovers automatically after temperature goes down						
ENVIRONMENT	WORKING TEMP.	0 ~ +50°C (Refer to output load derating curve)						
	WORKING HUMIDITY	20% ~ 90% RH non-condensing						
	STORAGE TEMP., HUMIDITY	-20 ~ +85°C, 10 ~ 95% RH						
	TEMP. COEFFICIENT	±0.03% / °C (0 ~ 40°C)						
VIBRATION	10 ~ 500Hz, 2G 10min./1cycle, period for 60min. each along X, Y, Z axes							
SAFETY & EMC	SAFETY STANDARDS	UL60950-1, CSA22.2, BSMI CNS14336 approved						
	WITHSTAND VOLTAGE	I/P-O/P:3KVAC						
	ISOLATION RESISTANCE	I/P-O/P:100M Ohms / 500VDC / 25°C / 70% RH						
	EMI CONDUCTION & RADIATION	Compliance to FCC part15 class B, EN55022, EN61204-3 class B, BSMI CNS13438						
	HARMONIC CURRENT	Compliance to EN61000-3-2,3						
EMS IMMUNITY	Compliance to EN61000-4-2,3,4,5,6,8,11, ENV50204, EN61204-3, light industry level, criteria A							
OTHERS	MTBF	1414.6Khrs min. MIL-HDBK-217F (25°C)						
	DIMENSION	65*47*26.5mm (L*W*H)						
	PACKING	0.15Kg ; 100pcs / 16Kg / CARTON						
CONNECTOR	PLUG	Standard type P1I: 2.1φ * 5.5φ * 9.5mm turning fork type, center positive for stock ; Other type available by customer requested						
	CABLE	Standard type UL1185 6ft (4FT only for 5V output) for stock ; Other type available by customer requested						
NOTE	1.All parameters are specified at 115VAC input, rated load, 25°C 70% RH ambient. 2.Ripple & noise are measured at 20MHz by using a 12" twisted pair terminated with a 0.1uf & 47uf capacitor. 3.Tolerance: includes set up tolerance, line regulation, load regulation. 4.Line regulation is measured from low line to high line at rated load. 5.Load regulation is measured from 10% to 100% rated load. 6.The over temperature protection (OTP) is the built-in function of the control IC (U1). The activating level described above is based on the specification provided by the IC manufacturer.							

Mechanical Specification

Unit:mm

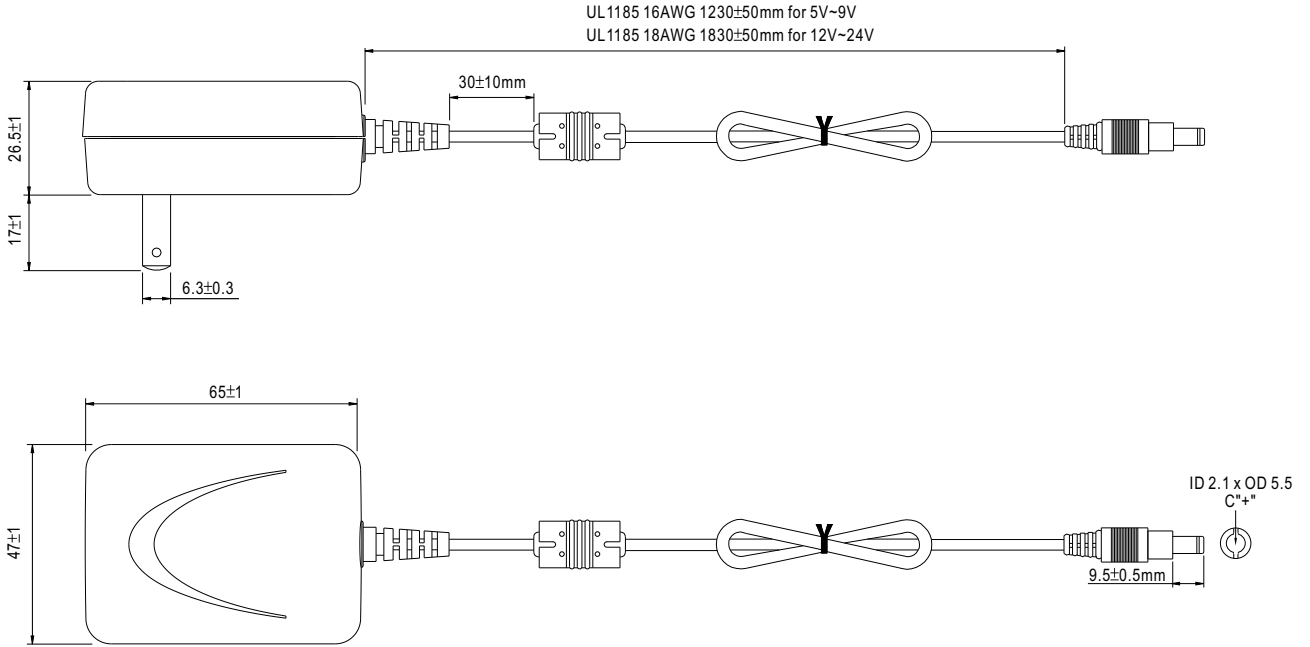

Plug Assignment

Standard plug: P11 (option)

P11	
P/N	OUTPUT
CENTER	+

Derating Curve

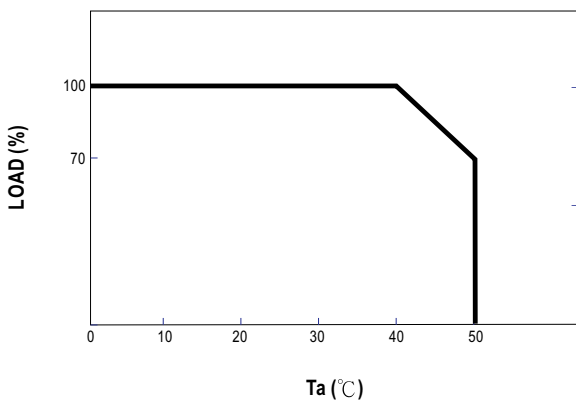

Static Characteristics(24V)

