



Features

- Wide input range 180 ~ 528VAC
- Built-in active PFC function
- High efficiency up to 94.5%
- -40°C ~ +70°C wide operating range
- Fanless design, cooling by free air convection
- Three in one dimming function (0~10Vdc or PWM signal or resistance)
- IP67 / IP65 design for indoor or outdoor installations
- Protections: Short circuit / Over current / Over voltage / Over temperature
- Withstand 5G vibration test
- Suitable for dry / damp / wet location
- Type “HL” for use in class I , Division 2 hazardous(Classified) location luminaires
- 5 years warranty (Note.10)

Applications

- LED street lighting
- LED high-bay lighting
- Parking space lighting
- LED fishing lamp
- LED greenhouse lighting
- Class I , Division 2 hazardous(Classified) location luminaires

Description

HVG-320 series is a high performance 320W AC-to-DC LED power supply featuring the high input voltage ranging from 180VAC through 528VAC. The working efficiency is up to 94.5%. The fully-potted silicone and the aluminum case facilitate the heat dissipation. HVG-320 is thus able to work at the temperature between -40°C and +70°C under free air convection. This series can withstand surge up to 4KV (EN61000-4-5) and is approved for IP65/IP67 protection level. These attributes all make HVG-320 perfectly fit the indoor/outdoor LED lighting application requiring remarkable reliability.

Model Encoding

HVG - 320 - 24 A

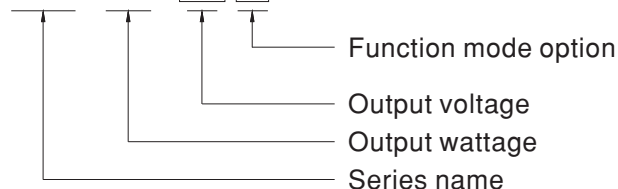

- A: Standard model, IP65, Io and Vo adjustable through built-in potentiometers.
- B: Standard model, IP67, 3 in 1 dimming function (0~10Vdc, 10V PWM signal and resistance)



SPECIFICATION

MODEL		HVG-320-24 □	HVG-320-30 □	HVG-320-36 □	HVG-320-42 □	HVG-320-48 □	HVG-320-54 □
OUTPUT	DC VOLTAGE	24V	30V	36V	42V	48V	54V
	CONSTANT CURRENT REGION <small>Note.4</small>	12 ~ 24V	15 ~ 30V	18 ~ 36V	21 ~ 42V	24 ~ 48V	27 ~ 54V
	RATED CURRENT	13.4A	10.7A	8.9A	7.6A	6.7A	6A
	RATED POWER	321.6W	321W	320.4W	319.2W	321.6W	324W
	RIPPLE & NOISE (max.) <small>Note.2</small>	150mVp-p	200mVp-p	250mVp-p	250mVp-p	250mVp-p	350mVp-p
	VOLTAGE ADJ. RANGE <small>Note.6</small>	21 ~ 26V	26 ~ 32V	32 ~ 39V	38 ~ 45V	43 ~ 52V	49 ~ 58V
	CURRENT ADJ. RANGE <small>Note.6</small>	6.7 ~ 13.4A	5.35 ~ 10.7A	4.45 ~ 8.9A	3.8 ~ 7.6A	3.35 ~ 6.7A	3 ~ 6A
	VOLTAGE TOLERANCE <small>Note.3</small>	±1.0%	±1.0%	±1.0%	±1.0%	±1.0%	±1.0%
	LINE REGULATION	±0.5%	±0.5%	±0.5%	±0.5%	±0.5%	±0.5%
	LOAD REGULATION	±0.5%	±0.5%	±0.5%	±0.5%	±0.5%	±0.5%
	SETUP, RISE TIME <small>Note.8</small>	500ms, 80ms /230VAC	500ms,80ms/347VAC/480VAC at full load ; B type	500ms, 280ms/230VAC	500ms,280ms/347VAC/480VAC at 95% load		
HOLD UP TIME (Typ.)	15ms at full load	480VAC / 347VAC					
INPUT	VOLTAGE RANGE <small>Note.5</small>	180 ~ 528VAC	254VDC ~ 747VDC				
	FREQUENCY RANGE	47 ~ 63Hz					
	POWER FACTOR (Typ.)	PF≥0.98/230VAC, PF≥0.98/277VAC, PF≥0.97/347VAC, PF≥0.95/480VAC at full load (Please refer to "Power Factor Characteristic" curve)					
	TOTAL HARMONIC DISTORTION	Total harmonic distortion will be lower than 20% when output loading is 50% or higher at 230VAC / 277VAC / 347VAC / 480VAC					
	EFFICIENCY (Typ.)	93%	93%	94%	94%	94.5%	94.5%
	AC CURRENT (Typ.)	1.1A / 347VAC	0.8A / 480VAC				
	INRUSH CURRENT(Typ.)	COLD START 50A(twidth=850)µs measured at 50% Ipeak at 480VAC					
	MAX. NO. of PSUs on 16A CIRCUIT BREAKER	2unit(circuit breaker of type B) / 4units(circuit breaker of type C) at 480VAC					
LEAKAGE CURRENT	<0.75mA / 480VAC						
PROTECTION	OVER CURRENT <small>Note.4</small>	95 ~ 108% Protection type : Constant current limiting, recovers automatically after fault condition is removed					
	SHORT CIRCUIT	Constant current limiting, recovers automatically after fault condition is removed					
	OVER VOLTAGE	27 ~ 33V	33 ~ 37V	40 ~ 46V	46.5 ~ 53V	53.5 ~ 60V	59 ~ 65V
		Protection type : Shut down and latch off o/p voltage, re-power on to recover					
OVER TEMPERATURE	Shut down and latch off o/p voltage, re-power on to recover						
ENVIRONMENT	WORKING TEMP.	-40 ~ +70°C (Refer to "Derating Curve")					
	WORKING HUMIDITY	20 ~ 95% RH non-condensing					
	STORAGE TEMP., HUMIDITY	-40 ~ +85°C, 10 ~ 95% RH					
	TEMP. COEFFICIENT	±0.03%/°C (0 ~ 60°C)					
	VIBRATION	10 ~ 500Hz, 5G 12min./1cycle, period for 72min. each along X, Y, Z axes					
SAFETY & EMC	SAFETY STANDARDS <small>Note.7</small>	UL8750 (type"HL"), CSA C22.2 No. 250.0-08, IP65 or IP67 approved					
	WITHSTAND VOLTAGE	I/P-O/P:3.75KVAC I/P-FG:2KVAC O/P-FG:1.5KVAC					
	ISOLATION RESISTANCE	I/P-O/P, I/P-FG, O/P-FG:100M Ohms / 500VDC / 25°C / 70% RH					
	EMC EMISSION	Compliance to FCC Part 15 Subpart B					
	EMC IMMUNITY	Compliance to EN61000-4-2,3,4,5,6,8,11, EN61547, light industry level (surge 4KV), criteria A					
OTHERS	MTBF	124.3K hrs min. MIL-HDBK-217F (25°C)					
	DIMENSION	262*90*43.8mm (L*W*H)					
	PACKING	2Kg; 8pcs/17Kg/0.92CUFT					
NOTE	<ol style="list-style-type: none"> All parameters NOT specially mentioned are measured at 347VAC input, rated load and 25°C of ambient temperature. Ripple & noise are measured at 20MHz of bandwidth by using a 12" twisted pair-wire terminated with a 0.1uf & 47uf parallel capacitor. Tolerance : includes set up tolerance, line regulation and load regulation. Please refer to "DRIVING METHODS OF LED MODULE". Derating may be needed under low input voltages. Please check the static characteristics for more details. A-Type only. Safety and EMC design refer to EN60598-1, subject CNS15233, GB7000.1, FCC part18. Length of set up time is measured at cold first start. Turning ON/OFF the power supply may lead to increase of the set up time. The power supply is considered as a component that will be operated in combination with final equipment. Since EMC performance will be affected by the complete installation, the final equipment manufacturers must re-qualify EMC Directive on the complete installation again. Refer to warranty statement. 						

Block Diagram

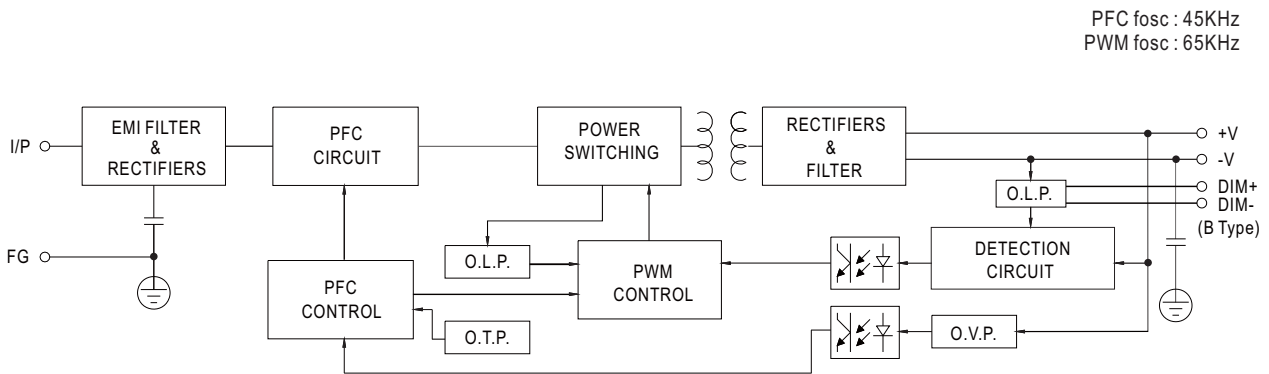

Derating Curve

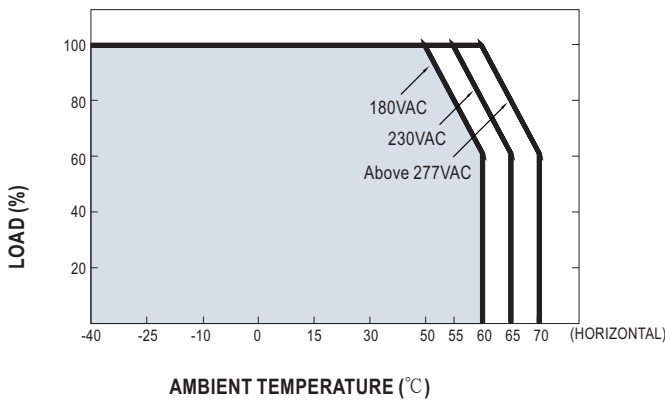

Static Characteristics

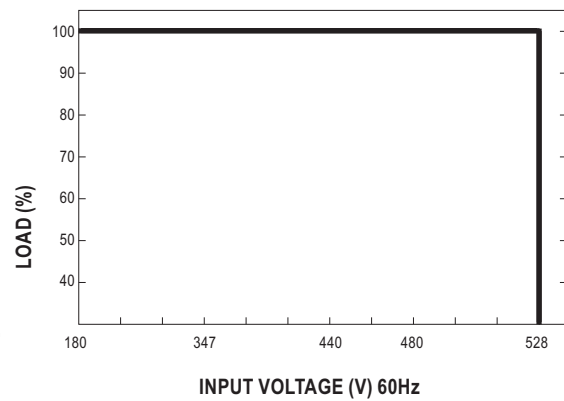

Power Factor Characteristic

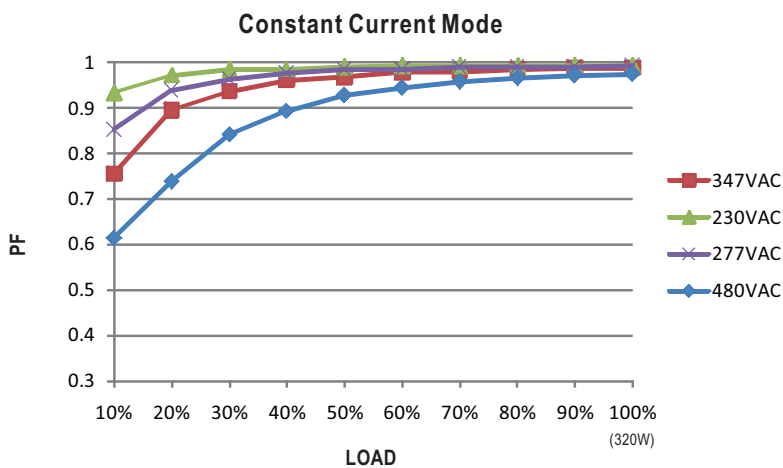

EFFICIENCY vs LOAD (54V Model)

HVG-320 series possess superior working efficiency that up to 94.5% can be reached in field applications.

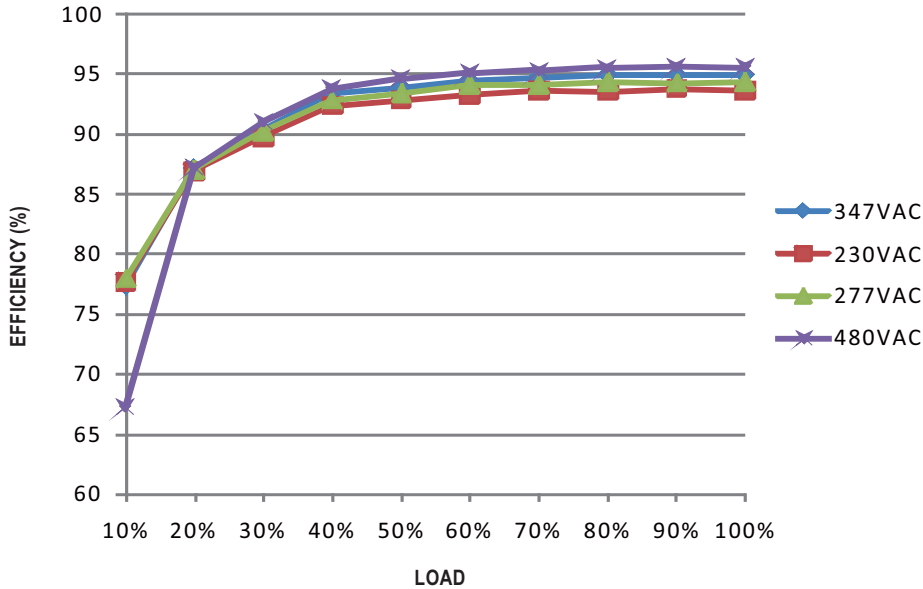

DRIVING METHODS OF LED MODULE

There are two major kinds of LED drive methods, "direct drive" and "with LED driver".

A typical LED power supply may either work in "constant voltage mode (C.V) or constant current mode (C.C)" to drive the LEDs.

Mean Well's LED power supply with C.V+ C.C characteristic can be operated at both C.V mode [with LED driver, at area (A)] and C.C mode [direct drive, at area (B)].

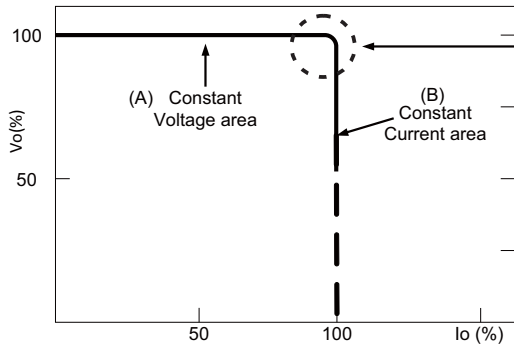

Typical LED power supply I-V curve

In the constant current region, the highest voltage at the output of the driver depends on the configuration of the end systems.

Should there be any compatibility issues, please contact MEAN WELL.

■ DIMMING OPERATION (for B Type only)

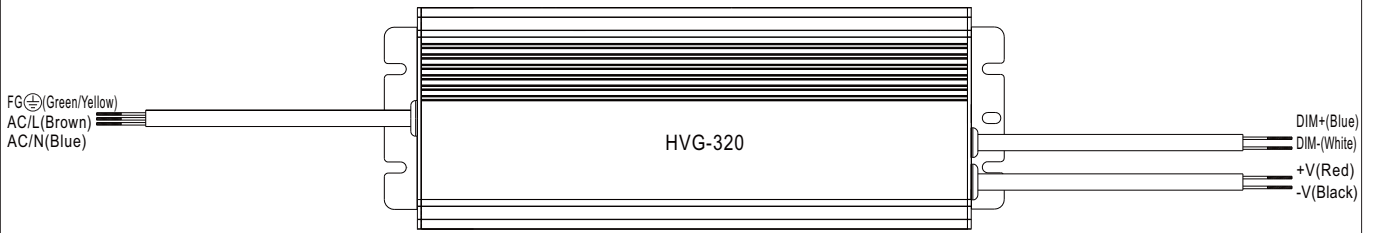

- ※ Built-in 3 in 1 dimming function, IP67 rated. Output constant current level can be adjusted through output cable by connecting a resistance or 0 ~ 10Vdc or 10V PWM signal between DIM+ and DIM-.
- ※ Please DO NOT connect "DIM-" to "-V".
- ※ Reference resistance value for output current adjustment (Typical)

Resistance value	Single driver	Short	10KΩ	20KΩ	30KΩ	40KΩ	50KΩ	60KΩ	70KΩ	80KΩ	90KΩ	100KΩ	OPEN
	Multiple drivers (N=driver quantity for synchronized dimming operation)	Short	10KΩ/N	20KΩ/N	30KΩ/N	40KΩ/N	50KΩ/N	60KΩ/N	70KΩ/N	80KΩ/N	90KΩ/N	100KΩ/N	-----
Percentage of rated current		0%	10%	20%	30%	40%	50%	60%	70%	80%	90%	100%	95%~108%

※ 0 ~ 10V dimming function for output current adjustment (Typical)

Dimming value	0V	1V	2V	3V	4V	5V	6V	7V	8V	9V	10V	OPEN
Percentage of rated current	0%	10%	20%	30%	40%	50%	60%	70%	80%	90%	100%	95%~108%

※ 10V PWM signal for output current adjustment (Typical): Frequency range : 100Hz ~ 3KHz

Duty value	0%	10%	20%	30%	40%	50%	60%	70%	80%	90%	100%	OPEN
Percentage of rated current	0%	10%	20%	30%	40%	50%	60%	70%	80%	90%	100%	95%~108%

◎ Dimming Characteristic

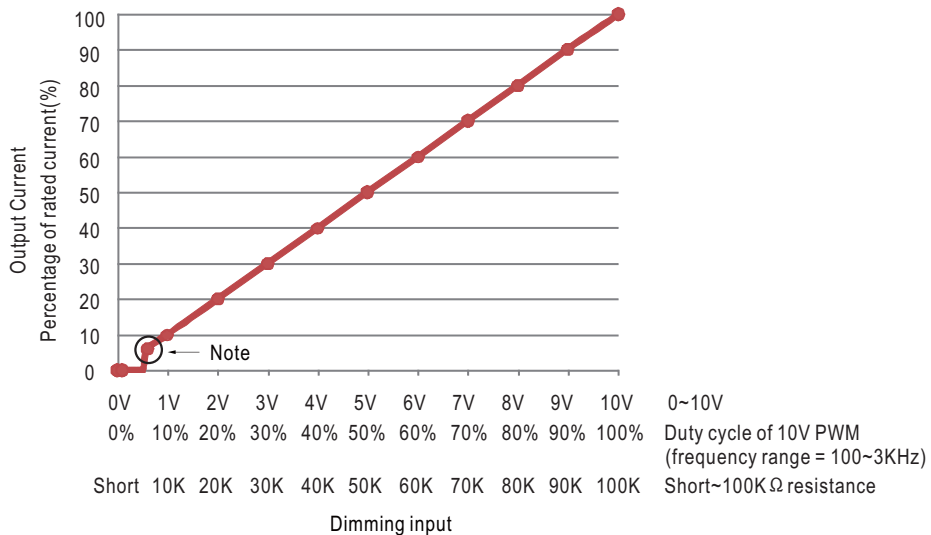

※ Note : The output current drops down to 0% when the dimming input is about 6KΩ or 0.6Vdc, or 10V PWM signal with 6% duty cycle.

Mechanical Specification

Case No. 202 Unit:mm

A-Type:(HVG-320-A)

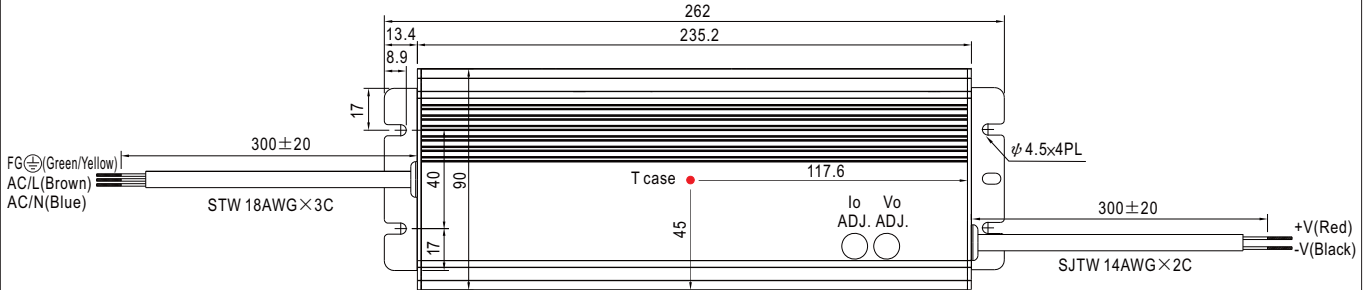

※ T case: Max. Case Temperature.

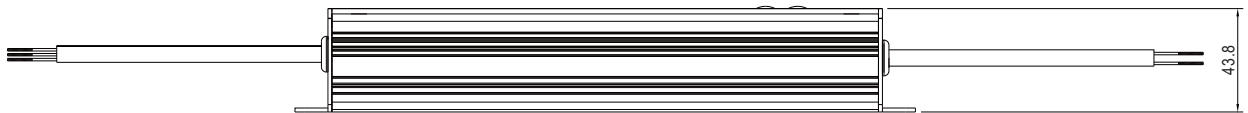

※ IP65 rated. Output voltage and constant current level can be adjusted through internal potentiometer.
(Can access by removing the rubber stopper on the case.)

B-Type:(HVG-320-B)

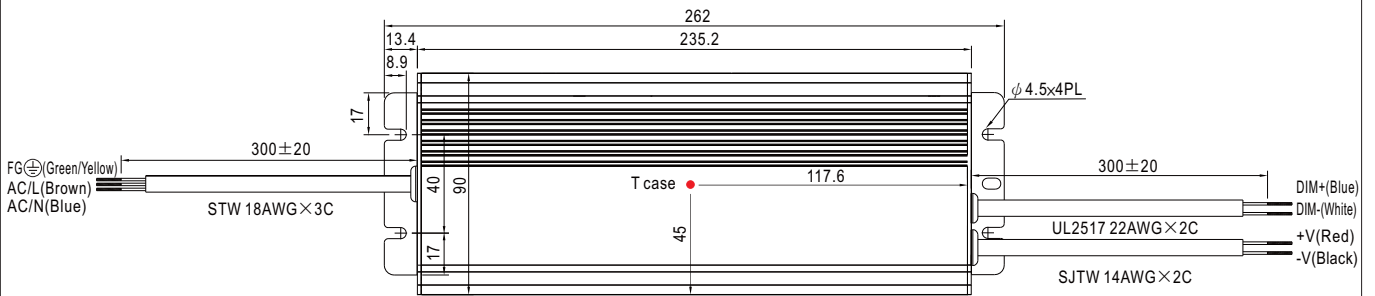

※ T case: Max. Case Temperature.



Installation Manual

Please refer to : <http://www.meanwell.com/webnet/search/InstallationSearch.html>