



■ Features :

- 115VAC or 230VAC models available
- Built-in active PFC function
- Constant current design
- Protections: Short circuit / Over temperature
- Cooling by free air convection
- Fully isolated plastic case
- Class II power unit, no FG
- Suitable for indoor LED lighting applications
- 100% full load burn-in test
- Low cost
- High reliability
- 3 years warranty



PLD-16-350 A : With AC input 90~ 135VAC.
 B : With AC input 180~ 295VAC.

SPECIFICATION

MODEL	PLD-16-350 <input type="checkbox"/>	PLD-16-700 <input type="checkbox"/>	PLD-16-1050 <input type="checkbox"/>	PLD-16-1400 <input type="checkbox"/>	
OUTPUT	RATED CURRENT	350mA	700mA	1050mA	1400mA
	OPERATING VOLTAGE RANGE	24 ~ 48V	16 ~ 24V	12 ~ 16V	8 ~ 12V
	CURRENT RANGE	0 ~ 350mA	0 ~ 700mA	0 ~ 1050mA	0 ~ 1400mA
	CURRENT ACCURACY	±5.0%			
	RATED POWER	16.8W	16.8W	16.8W	16.8W
	RIPPLE & NOISE (max.) Note.1	4.6Vp-p	2.7Vp-p	2.2Vp-p	2Vp-p
	NO LOAD OUTPUT VOLTAGE (max.)	63V	35V	25V	16V
	SETUP TIME	1000ms / 230VAC 2000ms / 115VAC at full load			
INPUT	FREQUENCY RANGE	47 ~ 63Hz			
	POWER FACTOR (Typ.)	PF>0.9/115VAC, PF>0.9/230VAC, PF>0.9/277VAC at full load (Please refer to "Power Factor Characteristic" curve)			
	EFFICIENCY (Typ.)	86%	86%	84%	84%
	AC CURRENT (Typ.)	0.4A/115VAC 0.2A/230VAC			
	INRUSH CURRENT(max.)	40A/230VAC			
	LEAKAGE CURRENT	<0.5mA / 240VAC			
PROTECTION	SHORT CIRCUIT	Hiccup mode, recovers automatically after fault condition is removed.			
	OVER TEMPERATURE	95°C±10°C (RTH1) Protection type : Shut down o/p voltage, re-power on to recover			
ENVIRONMENT	WORKING TEMP.	-30 ~ +60°C (Refer to "Derating Curve")			
	WORKING HUMIDITY	20 ~ 95% RH non-condensing			
	STORAGE TEMP., HUMIDITY	-40 ~ +80°C, 10 ~ 95% RH			
	TEMP. COEFFICIENT	±0.03%/°C (0 ~ 50°C)			
	VIBRATION	10 ~ 500Hz, 2G 12min./1cycle, period for 72min. each along X, Y, Z axes			
SAFETY & EMC	SAFETY STANDARDS	Design refer to UL8750, EN61347-1, EN61347-2-13			
	WITHSTAND VOLTAGE	I/P-O/P:3.75KVAC			
	ISOLATION RESISTANCE	I/P-O/P:100M Ohms / 500VDC / 25°C/ 70% RH			
	EMC EMISSION	Compliance to EN55015 (B type only), EN61000-3-2 Class C ; EN61000-3-3, FCC part5 Class B (A type only)			
	EMC IMMUNITY	Compliance to EN61000-4-2,3,4,5,6,8,11, EN61547, light industry level, criteria A			
OTHERS	MTBF	906.5Khrs min. MIL-HDBK-217F (25°C)			
	DIMENSION	84*57*29.5mm (L*W*H)			
	PACKING	0.19Kg; 72pcs/14.7Kg/0.92CUFT			
NOTE	1. Ripple & noise are measured at 20MHz of bandwidth by using a 12" twisted pair-wire terminated with a 0.1uf & 47uf parallel capacitor. 2. Direct connecting to LEDs is suggested, but is not suitable for using additional drivers.				

Mechanical Specification

Case No.PCD16A Unit:mm

A Type:(PLD-16_A)

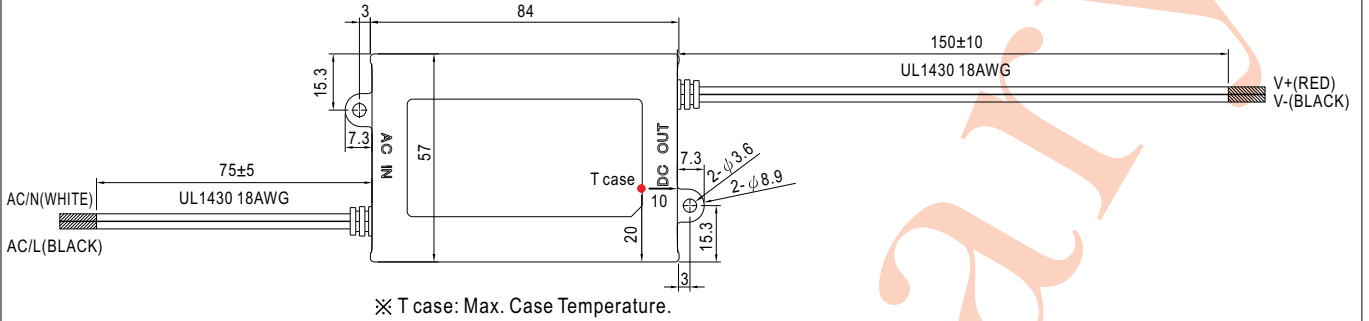

B Type:(PLD-16_B)

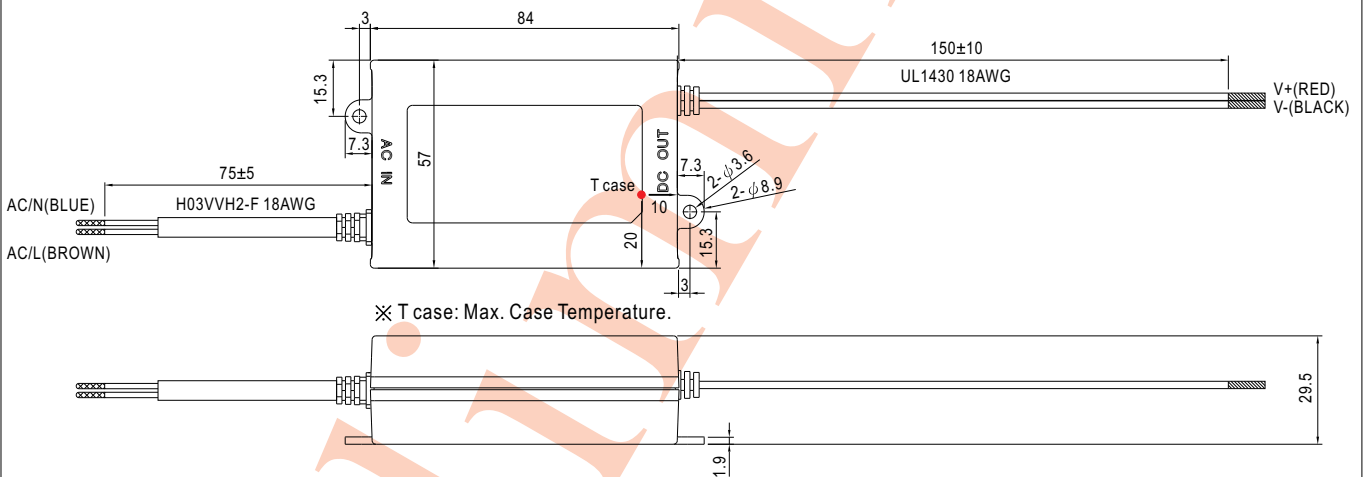

Block Diagram

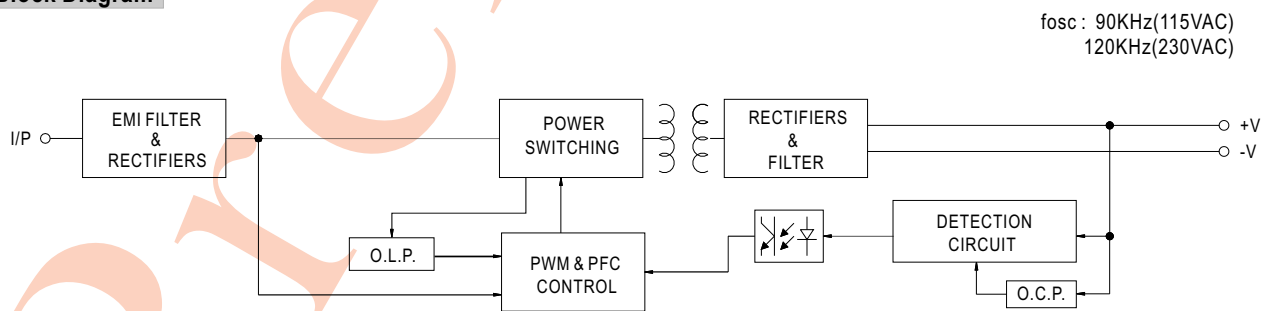

Derating Curve

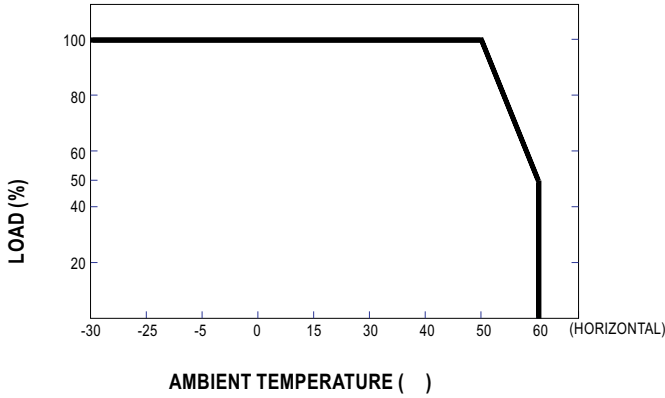

Static Characteristics

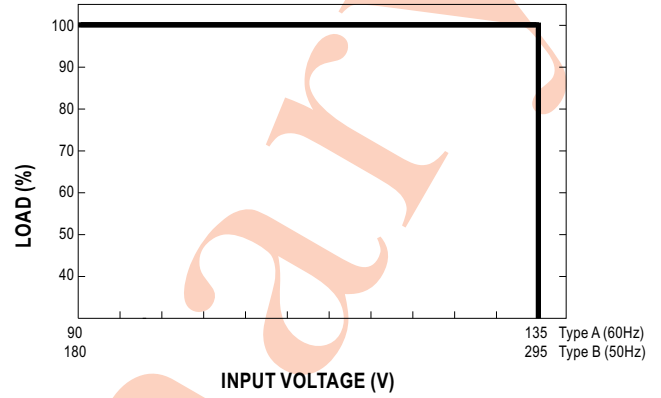

Power Factor Characteristic

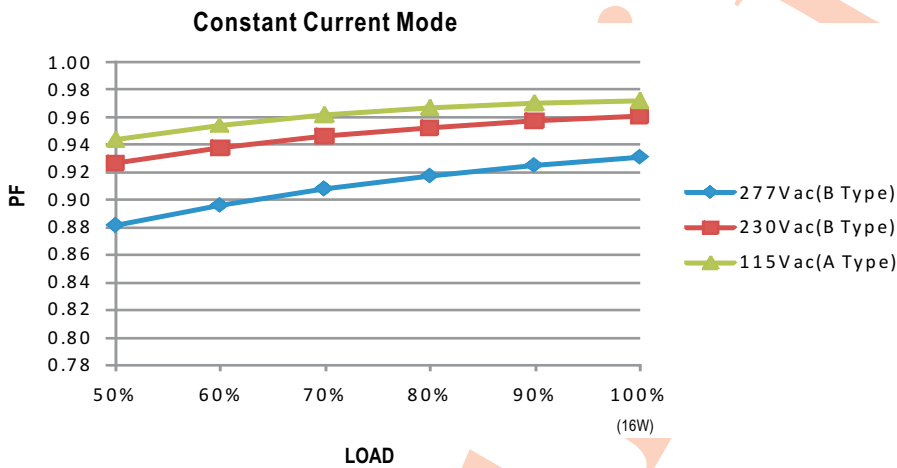

EFFICIENCY vs LOAD (PLD-16-350)

PLD-16 series possess superior working efficiency that up to 86% can be reached in field applications.

